

DDC Service instruction 2½" & 3" hose unit

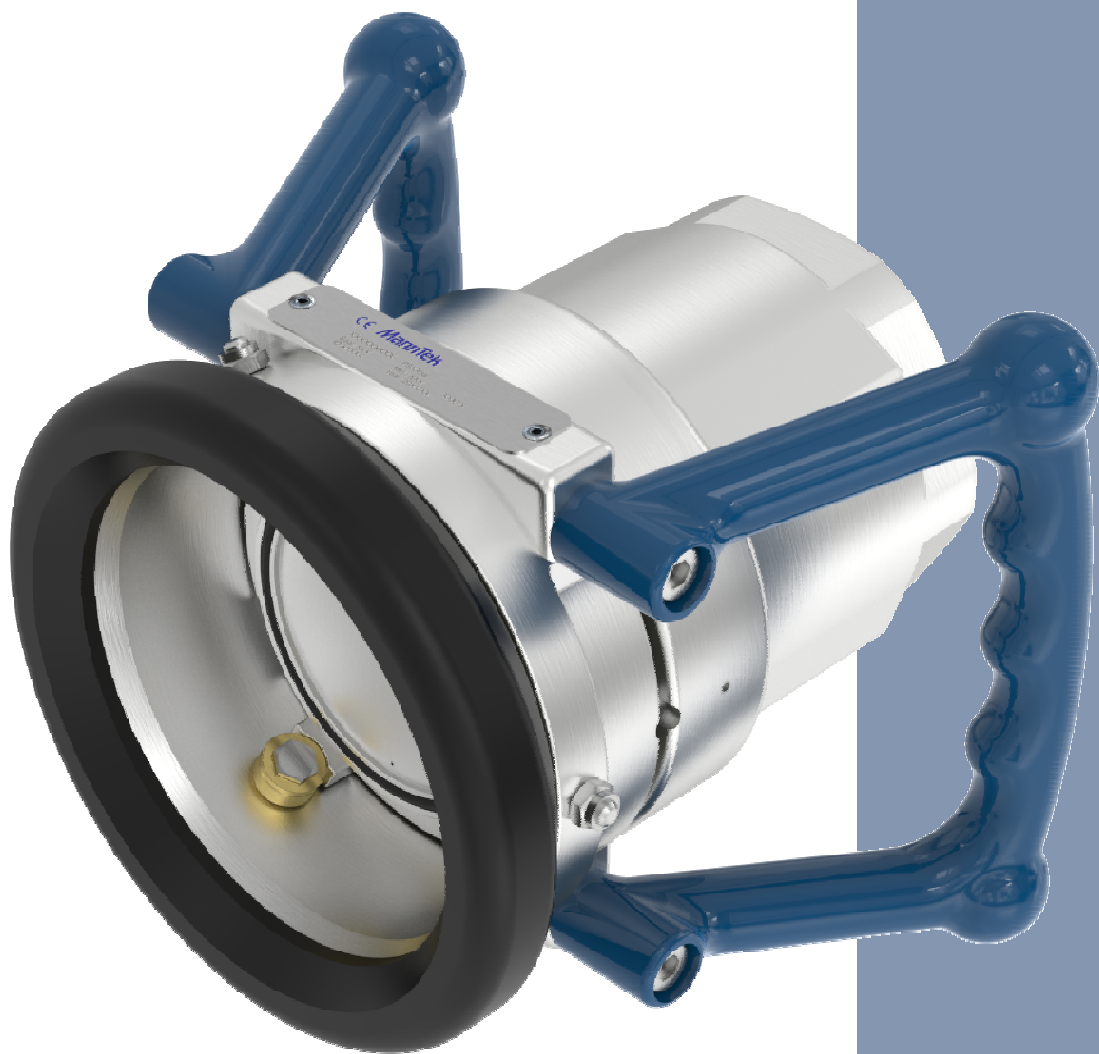

Quality, Health, Safety and Environment Policy

Our objectives are simple – no accidents, no occupational illness or work related accidents, no negative environmental impact and optimizing and continuously improving customer satisfaction wherever we operate.

Mariestad, February 28 2008



Tony Mann

What does this mean?

In our daily work to develop, sell, deliver and maintain our products this means to act as soon as we recognize a risk for:

- Delivery of products with insufficient technical quality
- Giving incorrect information
- Not complying with laws and regulations concerning our operation
- Causing negative environmental impact
- Causing occupational illness or accidents
- Not be able to keep promises on delivery terms (product and information)

To act, here means to point out the risk and to make sure we take a balanced decision to prevent what is undesired.

(This policy includes all that is traditionally covered in separate policies for quality, health, safety and environment)

HOSE UNIT 2½"-3"

MATERIAL: AL, BR, SS

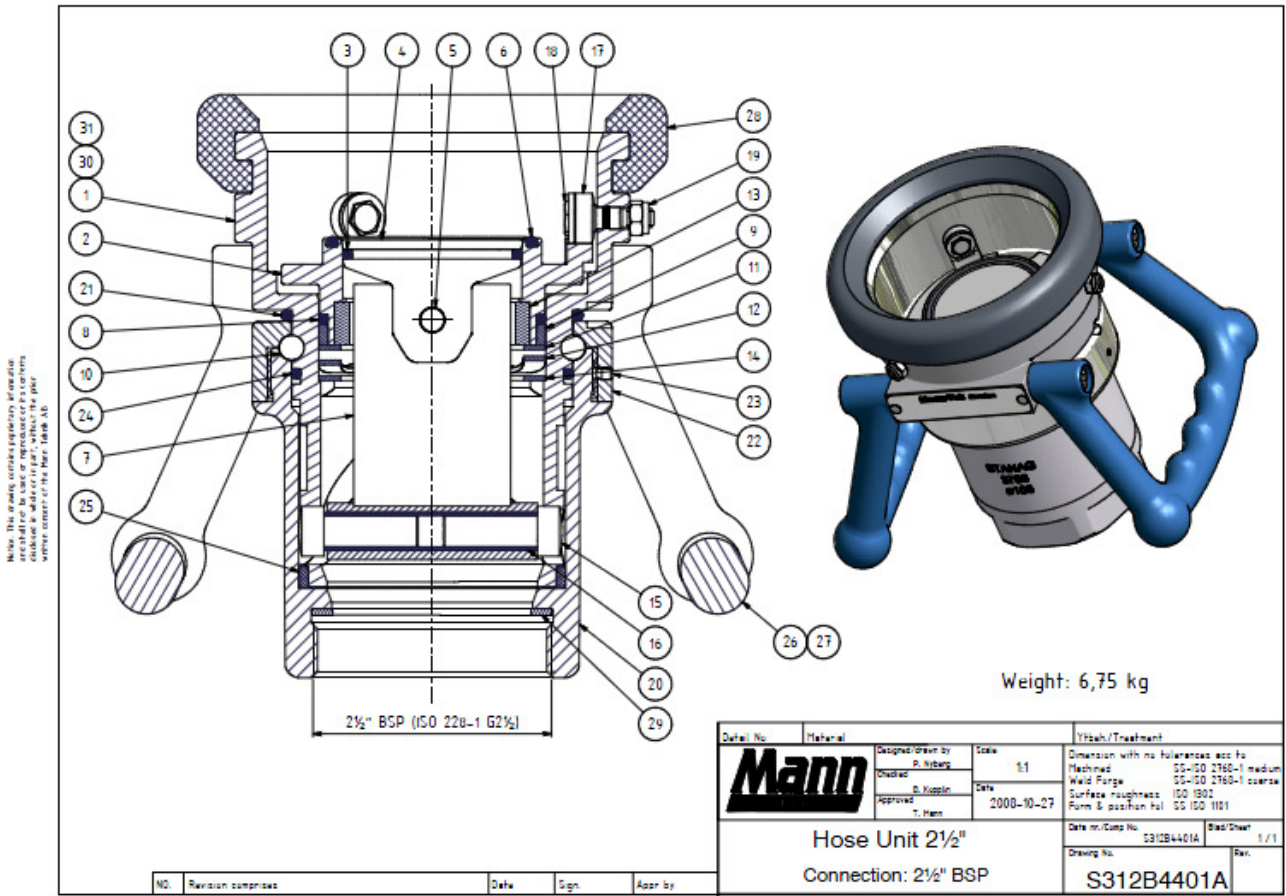

PARTS NEEDED FOR SERVICE: Spare part kit and O-ring kit (see page 4)

PERFORM A SERVICE: If leaking
Every year
Change of media



PLEASE NOTE!

Make sure that you are using the right type of O-rings and seals for the media you are using. We are using a standard silicone based grease for standard media, for special media please contact us.

MAINTENANCE AND SERVICE INSTRUCTION



Always depressurise the system and rinse off the parts before beginning any maintenance work. Use protective goggles. Do not handle O-ring seals if the material appears charred, gummy or sticky.



Use tweezers and wear neoprene or PVC gloves. Do not touch adjacent parts with unprotected hands. Rinse off the parts once again before starting the “daily inspection”

DAILY INSPECTION

1. Inspect the coupling surface for cleanliness and corrosion.
2. Inspect the O-ring in the house unit connection for serviceability and correct seating in the groove.
3. Inspect the hose unit swivel for free rotation.
4. Inspect the tank- and hose unit for faultlessness and external signs of seizure.
5. Take care that swivel sleeve is screwed on completely and lock screw is available and secured

THREE-MONTH INSPECTION

1. Exterior cleaning of the coupling halves with a neutral cleanser.
2. Careful “daily inspection” of cleaned units.

ONCE A YEAR

1. Exchange sealing and washer at least once a year.
2. Refill the hose unit ball bearing grooves with grease
3. Replace worn or damaged components. Repair procedures are straightforward and no special tools are required.

Check the state of the connection surface and verify that it is clean before proceeding with the connection.

Couple the repaired unit to a serviceable hose or tank unit as appropriate and check for correct operation of the valve actuating and bayonet locking mechanism. Couple and uncouple the unit(s) several times.

USE ONLY ORIGINAL MANNTEK SPARE PARTS FOR MAINTENANCE.

Spare part kit (S-S3-xx)
(S-S4-xx)
O-ring kit (O-S3-yy)
(O-S3-yy)

xx and yy means the material key according to the product catalogue. You will find it also as the 6th to 9th sign in the serial number (e.g. S312AxxyyB or S414AxxyyB).



Begin with unscrewing and remove the lock screw from the swivel ring.

Tool: Hexagon wrench No. 2



Mark the position of swivel sleeve against swivel ring with an Ø8 mm pin.
Unscrew and remove swivel sleeve from swivel ring.

Tool: Adjustable wrench



Change the PTFE ring (pos.25) on the top of the coupling body.

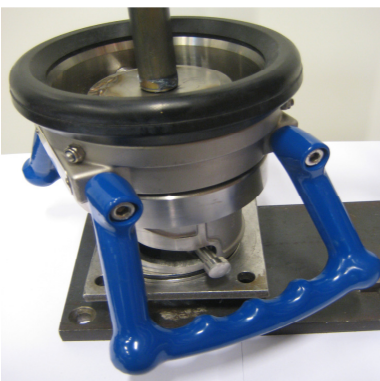

Remove the two shafts for piston guide, by applying pressure to the driving plate packet so that it moves down 2 mm. So that the driving plate packet is released from the rollers.

MannTek



Turn the driving plate to the position where the recess ends up under the rollers under pressure to the driving plate packet.

Remove the driving plate packet from the hose unit body.

Tool: Polygrip plier



If necessary change O-ring (pos.21) for dust –protection. Use grease on the new O-ring.

Dismount the handle before you change O-ring.

Tool: Allen key 6mm

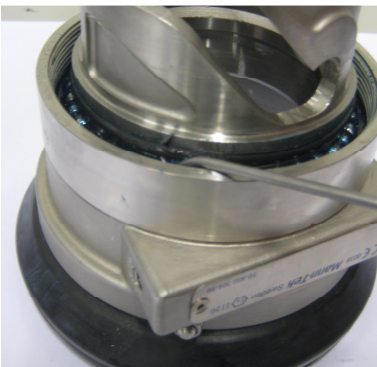

Change the O-ring (pos.24) from the groove in the coupling body. Use grease on the new part. Apply grease on the balls for best possible swivel rotation.

A mounting sleeve is recommended to mount the o-ring. If no sleeve is available a plastic strip can be taped around the body to cover the cam curves.



Change the three shafts (pos.18), locking nuts (pos.19) and rollers (pos.17) to new ones.

Tool: Standard wrench 10 mm

MannTek

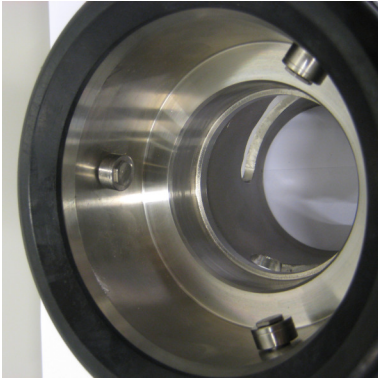

Check the rollers for easy rotation.



Change the O-ring (pos.8) and PTFE ring (pos.9) on the driving plate back side. Use grease on O-ring.

Make sure that the O-ring doesn't get twisted when mounting.



Change the PTFE bushing (pos.13) to new ones on both sides.



Change the O-ring (pos.6) on the driving plate front side. Use grease on O-ring.

Make sure that the O-ring doesn't get twisted when mounting.

MannTek



Change the O-ring (pos.3) on the piston. Use grease on the new O-ring. Make sure that the O-ring doesn't get twisted when mounting.

Press down the O-ring with your thumb. Make sure that the O-ring fits into the groove.



Change the PTFE bushing (pos.16) to new ones on both sides.



Before the coupling body places on the driving plate packet, make sure that the part where the upper cam curve ends, shall be placed exactly over one roll, and the heel on the driving plate packet should be placed under the hole for the shaft.

Place the coupling body over the driving plate packet. Grab the piston guide and turn the unit upside down.

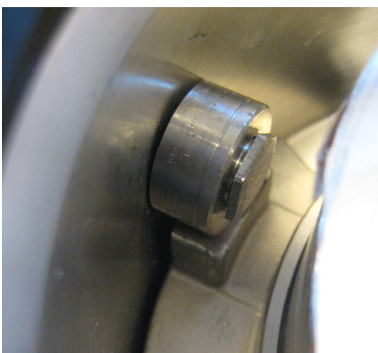

Press down and turn the driving plate to the position where the driving plate heels are placed under the rollers.

MannTek



Assemble the two shafts for piston guide when applying pressure to the driving plate packet

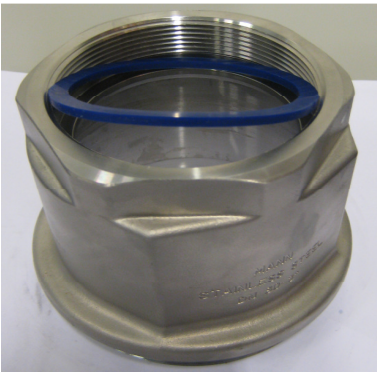

Place a new flat seal (pos.29) on the swivel sleeve. (Not needed when NPT-thread)



Place the swivel sleeve over the coupling body and screw in the swivel sleeve.

Take care that the markings you made in the beginning are aligning.

If necessary apply anti seize lube on the threads.



Use Loctite® 243 and screw the lock screw into the swivel ring without any force! Risk to deform the ball bearing! Apply sealing wax on the lock screw to prevent misuse.

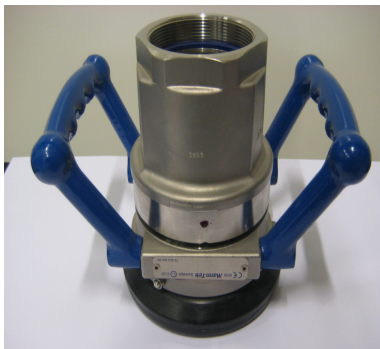

Finally, make a visual inspection that everything is in its place. Do also a test connection / disconnection with a tank unit that not has any fluid inside. If the coupling works alright you are ready to mount the hose unit on your hose again.

Loctite® is registered trademark of Henkel.

TEST PROCEDURE

After each service a pressure and tightness test of each coupling is mandatory. If only the O-Ring kit is replaced a seat tightness test is enough.

The following test parameters are in accordance with EN12266 and EN14432:

Test procedure	Test pressure	Acceptance criteria
Shell tightness test (Water)	1,5 x working pressure	No visually detectable leakage for the duration of the test
Seat tightness test (Air)	6 bar +/- 1 bar	
	Max 0,3 bar	

Table 1 – Test pressure

Nominal size	Minimum test duration
Up to DN 50	15 s
DN 65 to DN 150	60 s

Table 2 – Minimum test duration

TEST PROCEDURE:

- Fill the downstream valve cavity including, if appropriate, the cover cavity with the test fluid.
- Apply the test pressure specified in Table 1 in the direction tending to close the obturator.
- Maintain the test pressure for the test duration specified in Table 2.
- Determine the leakage rate.

If a pressure test should be achieved for the coupling mounted in an assembly follow the respective test instructions for the equipment but do not exceed 1,5 x Working Pressure of the coupling.

STORAGE

Store coupling in a dry, dust free, dark place, in ambient temperature.

© Copyright 2011 Mann Teknik AB. Mann Teknik AB reserves the right to make changes at any time in prices, materials, specifications and models and to discontinue models without notice or obligations.