

Notice: This drawing contains proprietary information and shall not be used or reproduced or its contents disclosed in whole or in part, without the prior written consent of the Mann Technik AB

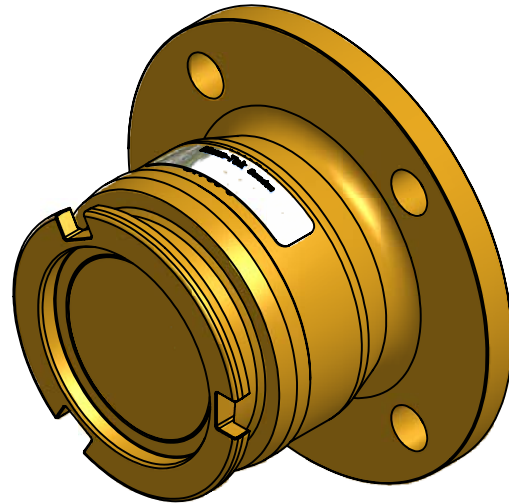
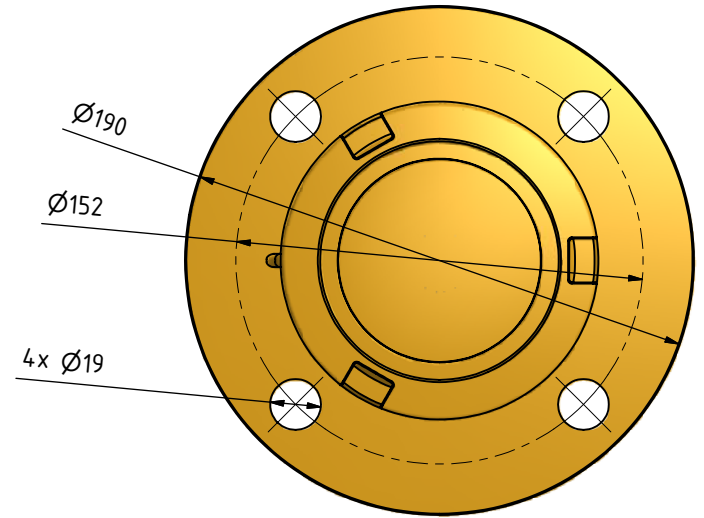
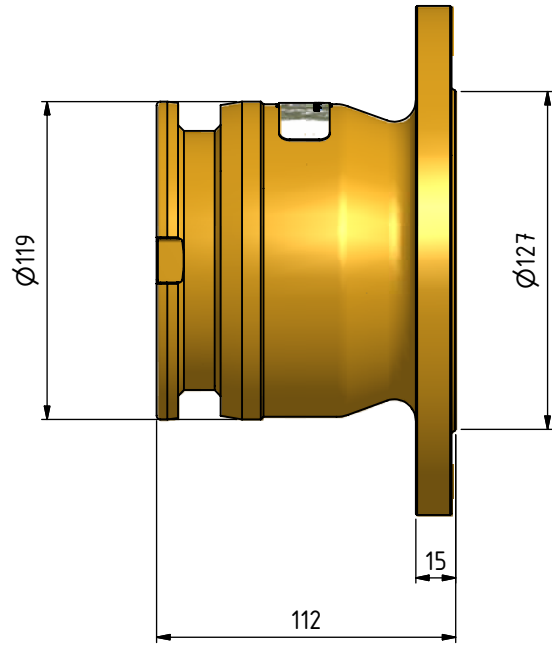

Dimensions are in metric.

Detail No:		Material		Ytbeh./Treatment	
<b>Mann</b> T e k	Designed/drawn by	Scale:		Dimension with no tolerances acc to Machined SS-ISO 2768-1 medium Weld Forge SS-ISO 2768-1 coarse Surface roughness ISO 1302 Form & position tol SS ISO 1101	
	Checked	1:2			
	Approved	Date			
	G. Kopplin	2008-12-15		Data nr./Comp No.	Blad/Sheet
	M. Bäckström			T461D2201	1 / 1
	T. Mann			Drawing No.	Rev.
<b>Tank Unit 3"</b>					
<b>Flange 3" ANSI 150 PSI</b>				<b>T461D2201-1</b>	

NO.	Revision comprises	Date	Sign.	Appr by
-----	--------------------	------	-------	---------